



Structures - B.Stichelbaut®



Watertight construction

- One-piece moulded flange and front dome.
- Viton® diaphragm with extreme expansion and retraction capacity : compensates the fluctuations in fluid volume caused by differences in temperature and atmospheric pressure, thus preventing the formation of bubbles.



Card

- Excellent readability whatever the weather conditions and light.
- Conical, highly stable, 81-mm apparent diameter.
- Individually balanced.
- Graduation every 5° and compact figures for easy reading.

3 lubber lines

For dependable readings even when steering windward.



Materials

- All parts fully UV-ray treated.
- Scratch resistant dome.

Lighting

12 V-bulb integrated in the front flange, spreading the illumination evenly over dome and card, and preventing eye strain and fatigue at night. Easy access to the light bulb from the front of the compass.

Mounting

Vertical bulkhead :

- Mini-Contest is compatible with drilling Ø of former model same size.
- Fits any bulkhead thickness :
 - Standard thickness (40 mm max) : the compass is secured with threaded rods
 - Thick or double bulkhead : the compass is secured with Parker screws on both sides of the bulkhead.

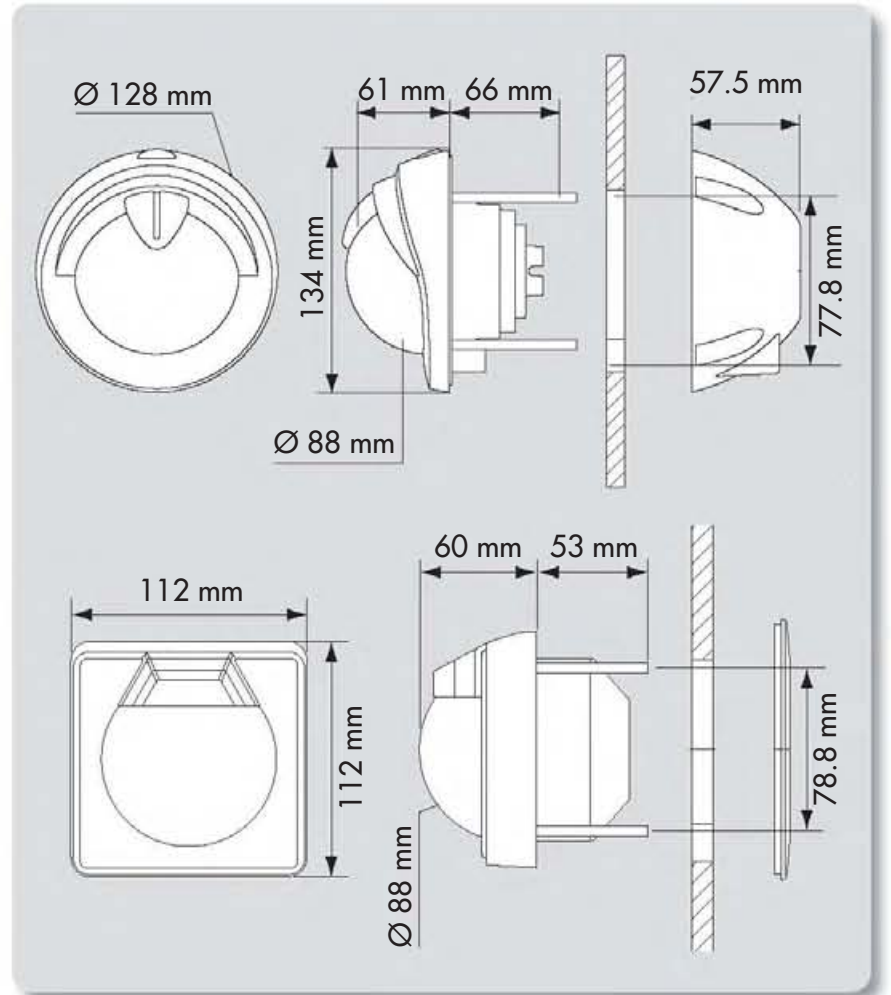

Options & accessories



- **Protective cover**
AdvanSea : white 29361



- **Protective cover**
Mini-Contest : white 55402
black 55599



- **Compensation :**
17673

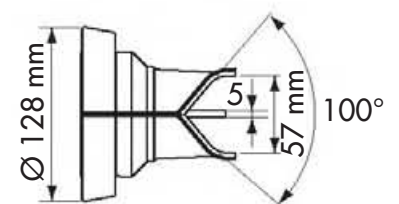

- **Mast mounting kit**
(Mini-Contest) : 55656

